

Form Service & Warranty Claim

DT SWISS

SCOTT NUDE

Please service!

This is a warranty claim!

Contact Distributor / Dealer:

name distributor / dealer:
ZIP / address:
country:
phone:
fax:
e-mail:

Sales receipt enclosed?

yes

no

In case the rework cannot be done under warranty, do you want us to contact you for an estimation of cost prior to service the product?

yes

no

bike model:
serial number shock:

Please describe precisely the shock's failure by marking the box(es).

air leak

oil leak

no damping / lockout function not working

rebound wheel stuck

strange noise while riding

remote system damage

worn ball bearings

others _____

Mark spot of failure in drawing to speed up your service! Thank you!

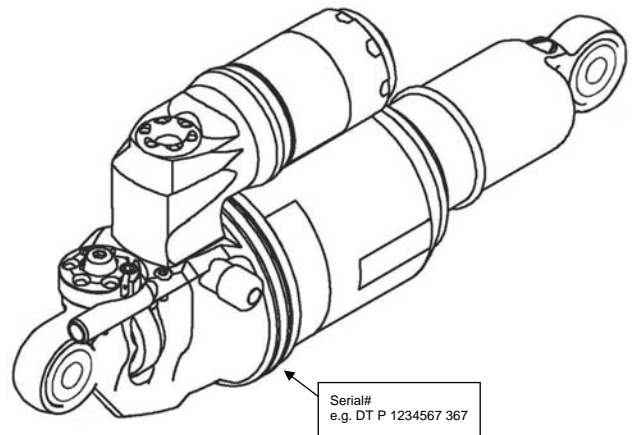

NOTE:

- Remove the shock's mounting hardware and the remote lever / cable before sending the shock! The DT Swiss Service Center will not be responsible for lost hardware / remote lever & cable.
- One complete Service & Warranty Claim form must be added per service / warranty claim!
- The DT Swiss Service Center will reject incomplete Service & Warranty Claims (e.g. missing sales receipt etc.)!
- For further information please read the DT Swiss Owners Manual of this product concerning DT Swiss Warranty regulations or visit www.dtswiss.com.